



A-1030-0



A-1030-2

특징 Feature

- A-1030-0: SEMI S8-0218(SESC6.8) 클린룸용 장갑 착용시 대응(2018년도판)
- A-1030-1·TMP: SEMI S8-0701(SESC6.8) 대응(2001년도판)
- A-1030-2·TMP: SEMI S8-0218(SESC6.9) 클린룸용 장갑 착용시 대응(2018년도판)
- 반광택으로 고급감 있는 외관과 부드러운 촉감입니다. (A-1030-TMP)
- A-1030-0: Compliant with SEMI S8-0218 (SESC 6.8) (2018 edition) when wearing clean room gloves
- A-1030-1,TMP: Compliant with SEMI S8-0701 (SESC 6.8) (2001 edition)
- A-1030-2,TMP: Compliant with SEMI S8-0218 (SESC 6.9) (2018 edition) when wearing clean room gloves
- Semi-gloss, high-grade exterior and smooth feel. (A-1030-TMP)

크레몬

롤러 잠금

특장 밀폐 핸들

프리저 밀폐

평면 스윙

평면 핸들

팝 핸들

리프트 핸들

어저스터 핸들

래치식

스내치

링크

후크식

록 핸들

L형 핸들

T형 핸들

원형 소형

누름 버튼

손잡이

노브

스톱퍼 로드

조인트 링크

와이어

[A-1030-0]

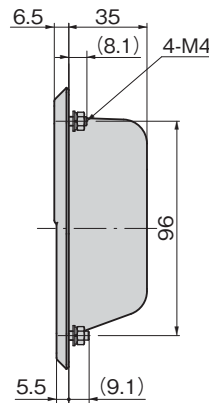
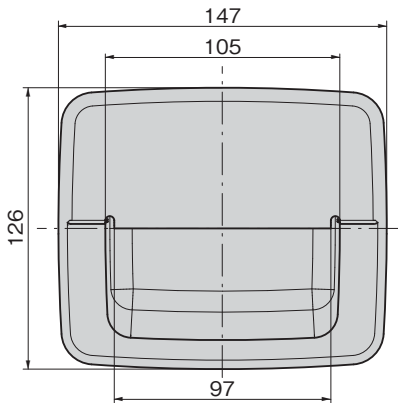

[A-1030-1·2]

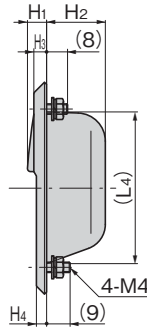
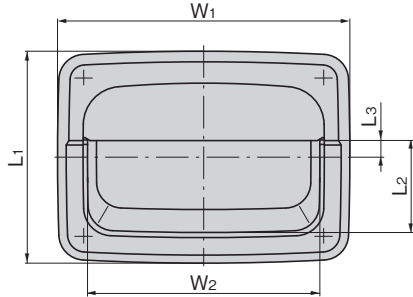

- 사양
- 재질: 냉간 압연 스테인레스 강판(SUS304)
 - 표면 마무리: 비즈샷 처리

[A-1030-TMP]

- 사양
- 재질: 냉간 압연 스테인레스 강판(SUS304)
 - 표면 마무리: 화학 연마(TMP)
- 용도
- 반도체 제조장치·계측기기

[A-1030]

- Specifications
- Material: Cold rolled stainless steel plate (SUS304)
 - Finish: Beading process

[A-1030-TMP]

- Specifications
- Material: Cold rolled stainless steel plate (SUS304)
 - Finish: Chemical polishing (TMP)
- Specific-use
- Semiconductor production equipment or measuring equipment

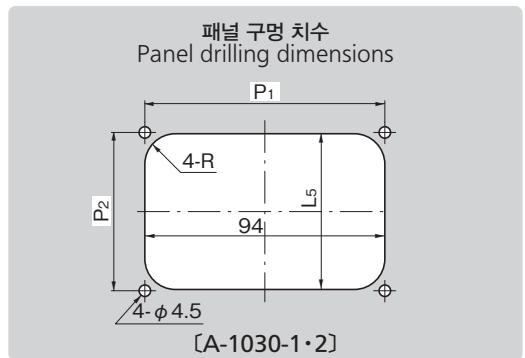
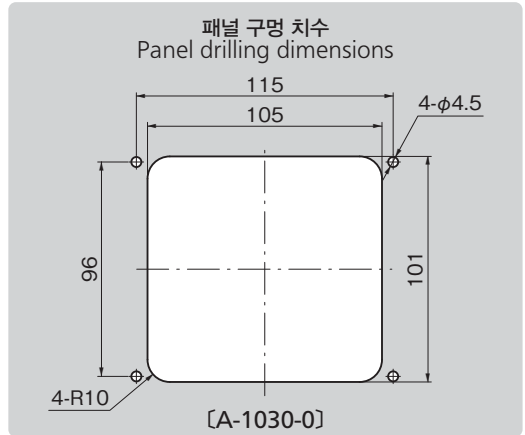

참고 단면도 Reference cross section

[A-1030-0]

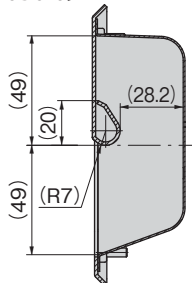

[A-1030-1·2]

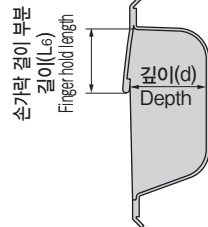

상품번호 Product No.	RoHS 10	L1	L2	L3	L4	L5	L6	H1	H2	H3	H4	W1	W2	P1	P2	(d)	R	제품질량(g) Mass	코드 Code	
A-1030-0	●	상기 도면에 따름 See drawings above																	340	04685
A-1030-1	●	120	42	4	91	95	50	9.2	47	6.5	5.5	133	92	105	90	50	10	310	03516	
A-1030-1-TMP	●	120	42	4	91	95	50	9.2	47	6.5	5.5	133	92	105	90	50	10	310	04611	
A-1030-2	●	83	36	6.5	60	61	22.5	7.5	23	5	4	114.5	91	94	62	25	12	150	03514	
A-1030-2-TMP	●	83	36	6.5	60	61	22.5	7.5	23	5	4	114.5	91	94	62	25	12	150	04612	

●: RoHS10 대응품 ▲: RoHS10에 대응 가능합니다.