

## AC-25-YJ

철제

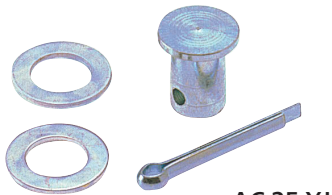
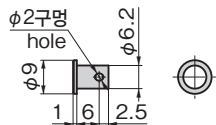
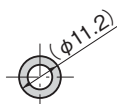
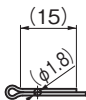
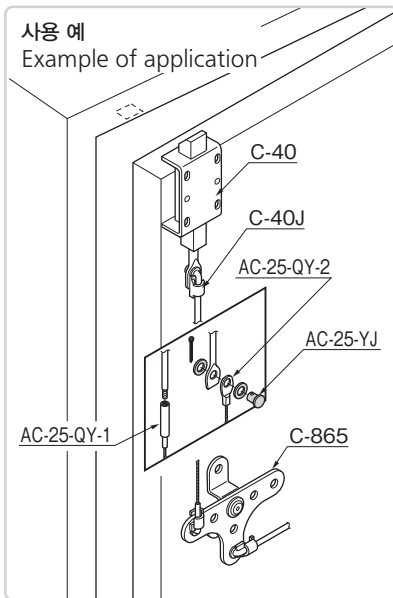

AC-25-YJ

[ 핀 ]  
Pin[ M6용 와셔 ]  
Washer for M6[ 코퍼 핀 공칭 직경 2 ]  
Cotter pin nominal 2사용 예  
Example of application

## 특징 Feature

- 와이어를 간단히 접속할 수 있는 조인트입니다.
- A wire can be easily connected to this joint.

## 사양

- 재질: 핀/일반 구조용 압연 강재(SS)  
워셔/냉간 압연 강판(SPCC)  
코퍼 핀/연강선재(SWRM)
- 표면 마무리: 아연 도금 크로메이트 처리 (MFZn-C)
- 제품질량: 3g

Specifi-  
cations

- Material: Pins: Rolled steel for general structure (SS)  
Plain washers: Cold rolled steel plate (SPCC)  
Split pins: Mild steel wire (SWRM)
- Finish: Zinc plating chromate treatment (MFZn-C)
- Mass: 3g

와이어 조인트  
WIRE JOINTS

상품번호 Product No.	RoHS 10	코드 Code
AC-25-YJ	●	01981

● : RoHS10 대응품

▲ : RoHS10에 대응가능합니다.