

# B-77-MD

철재



B-77-MD-10



B-77-MD-11



B-77-MD-14

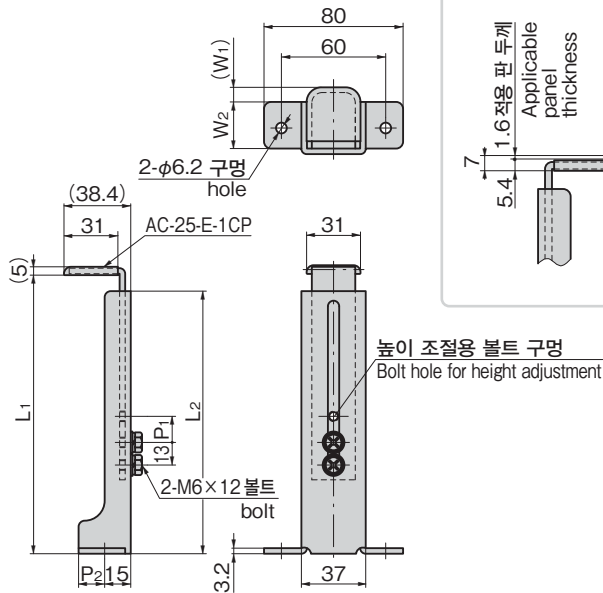

### CP-420-MD부착 이미지 Mounting example

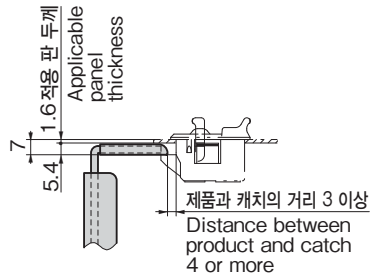

## 슬라이드식 포스트 경첩 SLIDE POST HINGES

### 특징 Feature

- CP-420-MD(1082페이지)와 조합해서 사용할 수 있습니다.
- 배전반, 분전반의 중판(장식판)의 높이를 자유롭게 조절할 수 있습니다.
- Can be used together with CP-420-MD. See page 1082.
- Height of the inside plate(dressing plate) for power/distribution or other boards can be adjusted.

사양	<ul style="list-style-type: none"> <li>● 재질: 본체/열간 압연 강판(SPHC) AC-25-E-1CP/폴리프로필렌(PP)</li> <li>● 표면 마무리: 아연 도금 크로메이트 처리(MFZn-C)</li> </ul>
용도	● 배분전반, 제어반, 점검구
비고	● 높이 조절용 볼트 구멍은 3개 있습니다. 부착 높이에 따라 2개의 볼트로 고정하십시오.
Specifications	<ul style="list-style-type: none"> <li>● Material: Main body: Hot rolled steel plate (SPHC) AC-25-E-1CP: Polypropylene (PP)</li> <li>● Finish: Zinc plating chromate treatment (MFZn-C)</li> </ul>
Specific-use	● Power/distribution boards, control boards and inspection entrance
Remarks	● Three bolt holes provided for height adjustment. Fix in place with two bolts according to installation height.

상품명 Product No.	RoHS 10	L1	L2	(W1)	W2	P1	P2	제품질량(g) Mass	코드 Code
B-77-MD-10	●	160~238	151	8.4	26.8	15	15	352	13438
B-77-MD-11	●	100~160	91	8.4	26.8	15	15	258	13437
B-77-MD-14	●	70~100	61	13.4	21.8	15	10	170	13419
B-77-MD-15	●	55~70	46	13.4	21.8	10	10	147	13420

●: RoHS10 대응품 ▲: RoHS10에 대응 가능합니다.

특수 경첩  
토르크 경첩  
지주  
주변기기 (B)