

C-846-3-R

특징 Feature

- 진동·충격에 강한 설계입니다.
- 중형 도어의 원터치 록에 최적입니다.
- 박형에 부착이 간단합니다.
- 우측용·좌측용(본 그림 및 사진은 모두 우측용입니다.)
- Designed to be highly resistant to vibration and impact.
- Suitable as one touch lock for the medium size door.
- Thin and installation is easy.
- For the right-hand or left-hand use. (The photo and drawing show the right-handed one)

사양	● 재질: 냉간 압연 강판(SPCC) ● 표면 마무리: 본체/아연 도금 크로메이트 처리(MFZn-C) 캄부/담금질 처리
용도	● 특장차·건설기계·버스
비고	● 스트라이커는 부속되어 있지 않습니다.
Specifications	● Material: Cold rolled steel plate (SPCC) ● Finish: Main unit: Zinc plating chromate treatment (MFZ-C) Cams: Quenching
Specific-use	● Specially equipped vehicles, construction machinery, buses.
Remarks	● The striker is not included.

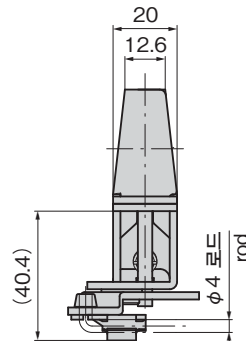
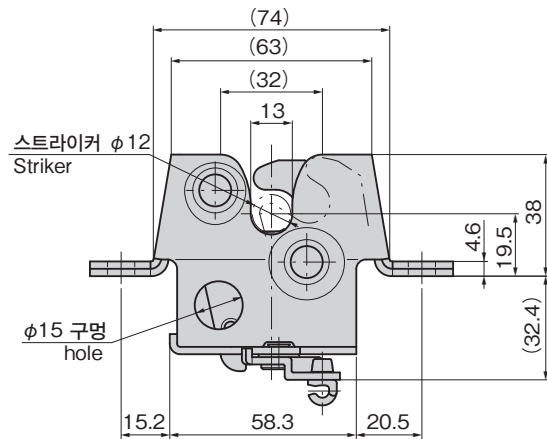
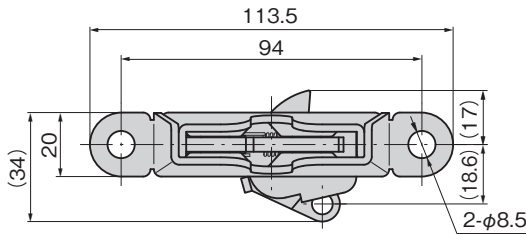

사용 로드 접속부 가공도
Figure of machining rod for connection

상품번호 Product No.	RoHS 10	제품질량(g) Mass	코드 Code
C-846-3-L	●	270	22190
C-846-3-R	●	270	22191

●: RoHS10 대응품
▲: RoHS10에 대응 가능합니다.

