

C-1029
스텐레스제

C-1029-S-M
스텐레스제

C-1029-M
스텐레스제

C-29
황동제

C-29-M
황동제



장식나사·와셔
SCREWS / WASHERS

잠금장치·주변기기

화스너

래치 자물쇠

도어 캐치

스내치
록

컨트롤
센터

파이프
관련 쇠장구

그레이팅
록

공업용
자물쇠

전자파
대책

패킹

창틀·
카드 홀더

고무 다리
그로메트
(Grommet)

주변기기
(C)

충전기용
쇠장식

프리저
쇠장식

래싱
시스템

PERIPHERA EQUIPMENT



C-1029-6-25



C-29-6-25



C-29-3-15



C-29-M8



C-1029-S-M6



C-1029-M3

[장식나사]
Dressing screw

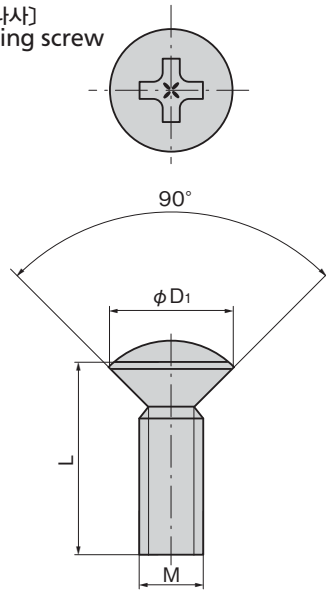

[장식나사]

- 사양
- 재질: C-1029/스텐레스 강봉(SUS304)
C-29/황동선(C2700W)
 - 표면 마무리: C-29/크롬 도금(MBCr)

[Dressing screw]

- Specifications
- Material: C-1029: Stainless steel bar (SUS304)
C-29: Brass bar (C2700W)
 - Finish: Chrome plating (MBCr)

[장식와셔]

- 사양
- 재질: C-1029-S-M/스텐레스 소결(분말)
(SUS304L)
C-1029-M/냉간 압연 스텐레스 강판
(SUS304)
C-29-M/쾌삭 황동봉(C3602BD)
 - 표면 마무리: C-1029-S-M/광택 배럴 연마
C-29-M/크롬 도금(MBCr)

[Dressing washer]

- Specifications
- Material: C-1029-S-M: Stainless steel sintered
(SUS304L)
C-1029-M: Cold rolled stainless steel
plate (SUS304)
C-29-M: Free cutting brass bar (C3602BD)
 - Finish: C-1029-S-M: Gloss barrel buffing
C-29-M: Chrome plating (MBCr)

빠짐 방지 와셔
CP-29-PA를 사용할 수 있습니다
(1338 페이지 참조)
Pull out prevention
washer CP-29-PA can be
used (see page 1338)



[장식와셔]
Dressing washer

[C-1029-M□용]
(프레스제)
Press

[C-1029-S-M□용]
(소결제)
Sintered
[C-29-M□용]
(황동)
Brass

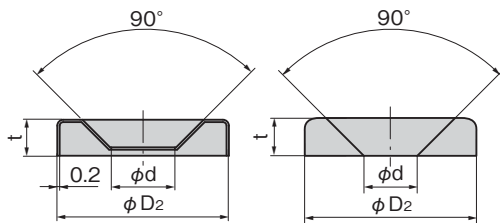
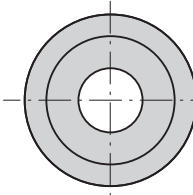
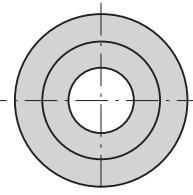

장식와셔(프레스제) Dressing washer (Press)

상품번호 Product No.	RoHS 10	φD ₂	φd	t	제품질량(g) Mass	코드 Code
C-1029-M3용	●	9.5	3.3	2.2	35/100개	20823
C-1029-M4용	●	11.5	4.3	2.3	25/100개	20824
C-1029-M5용	●	14.3	5.3	3	40/100개	20825
C-1029-M6용	●	16	6.3	3.2	55/100개	20826

장식와셔(소결제) Dressing washer (Sintered)

상품번호 Product No.	RoHS 10	φD ₂		φd		t		제품질량(g) Mass		코드 Code	
		SUS	황동 Brass	SUS	황동 Brass	SUS	황동 Brass	SUS	황동 Brass	SUS	황동 Brass
C-1029-S-M3	●	10	10	3.5	3.5	2	2	0.8	1	22140	20141
C-1029-S-M4	●	12	12	4.5	4.5	2.5	2.5	1.3	1.5	22141	20142
C-1029-S-M5	●	14	14	6	5.5	3	3	2	2	22142	20143
C-1029-S-M6	●	16	16	7	6.5	3.5	3.5	3	3	22143	20144
C-1029-S-M8	●	22	22	9	8.5	5	4.5	8	8	22144	20145

●: RoHS10 대응품 ▲: RoHS10에 대응 가능합니다.

장식나사 Dressing screw

(ISO)

상품번호 Product No.	RoHS 10	황동 Brass	φD ₁	제품질량(g) Mass	코드 Code	
					SUS	황동 Brass
C-1029-3-10	●	●	6	1	20803	20121
C-1029-3-15	●	●		1	20804	20122
C-1029-3-20	●	●		1.5	20805	20123
C-1029-3-25	●	●		1.5	20806	20124
C-1029-4-10	●	●	8	1.5	20807	20125
C-1029-4-15	●	●		2	20808	20126
C-1029-4-20	●	●		2.5	20809	20127
C-1029-4-25	●	●		2.5	20810	20128
C-1029-5-10	●	●	10	2.5	20811	20129
C-1029-5-15	●	●		3	20812	20130
C-1029-5-20	●	●		3.5	20813	20131
C-1029-5-25	●	●		4.5	20814	20132
C-1029-6-10	●	●	12	3	20815	20133
C-1029-6-15	●	●		4.5	20816	20134
C-1029-6-20	●	●		5	20817	20135
C-1029-6-25	●	●		6	20818	20136
C-1029-8-10	●	●	16	7.5	20819	20137
C-1029-8-15	●	●		10	20820	20138
C-1029-8-20	●	●		11	20821	20139
C-1029-8-25	●	●		15	20822	20140