

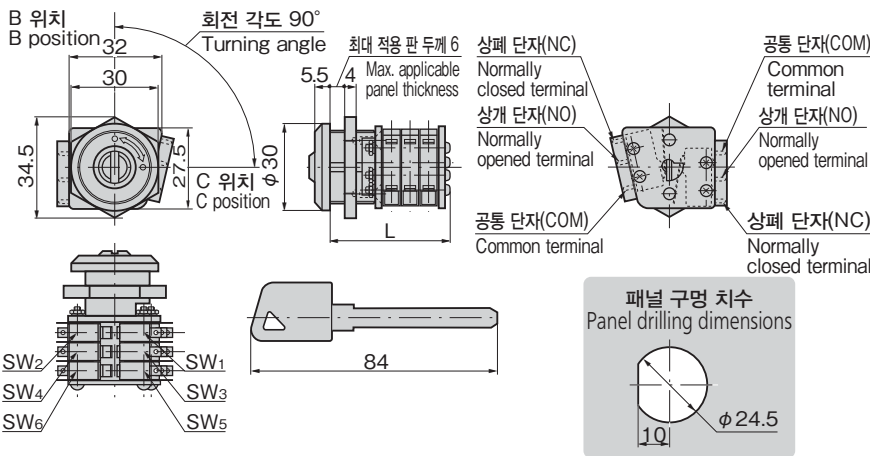

S-102



키 No.0102
Key



■S-102 열쇠 초기 번호 및 조합표 S-102 key initial No. and combination table

S-102-6(63가지용) for 63 sets

S-102-2(3가지용) for 3 sets

번호 No.	코드 Code	C 위치의 스위치 상태 Switch status at C position						번호 No.	코드 Code	C 위치의 스위치 상태 Switch status at C position					
		SW ₁	SW ₂	SW ₃	SW ₄	SW ₅	SW ₆			SW ₁	SW ₂	SW ₃	SW ₄	SW ₅	SW ₆
001	70650	ON	ON	ON	ON	ON	ON	201	70682	ON	ON	ON	ON	OFF	ON
002	70651	OFF	ON	ON	ON	ON	ON	202	70683	OFF	ON	ON	ON	OFF	ON
003	70652	ON	OFF	ON	ON	ON	ON	203	70684	ON	OFF	ON	ON	OFF	ON
004	70653	OFF	OFF	ON	ON	ON	ON	204	70685	OFF	OFF	ON	ON	OFF	ON
005	70654	ON	ON	OFF	ON	ON	ON	205	70686	ON	ON	OFF	ON	OFF	ON
006	70655	OFF	ON	OFF	ON	ON	ON	206	70687	OFF	ON	OFF	ON	OFF	ON
007	70656	ON	OFF	OFF	ON	ON	ON	207	70688	ON	OFF	OFF	ON	OFF	ON
008	70657	OFF	OFF	OFF	ON	ON	ON	208	70689	OFF	OFF	OFF	ON	OFF	ON
009	70658	ON	ON	ON	OFF	ON	ON	209	70690	ON	ON	ON	OFF	OFF	ON
010	70659	OFF	ON	ON	OFF	ON	ON	210	70691	OFF	ON	ON	OFF	OFF	ON
011	70660	ON	OFF	ON	OFF	ON	ON	211	70692	ON	OFF	ON	OFF	OFF	ON
012	70661	OFF	OFF	ON	OFF	ON	ON	212	70693	OFF	OFF	ON	OFF	OFF	ON
013	70662	ON	ON	OFF	OFF	ON	ON	213	70694	ON	ON	OFF	OFF	OFF	ON
014	70663	OFF	ON	OFF	OFF	ON	ON	214	70695	OFF	ON	OFF	OFF	OFF	ON
015	70664	ON	OFF	OFF	OFF	ON	ON	215	70696	ON	OFF	OFF	OFF	OFF	ON
016	70665	OFF	OFF	OFF	OFF	ON	ON	216	70697	OFF	OFF	OFF	OFF	OFF	ON
101	70666	ON	ON	ON	ON	ON	OFF	301	70698	ON	ON	ON	ON	OFF	OFF
102	70667	OFF	ON	ON	ON	ON	OFF	302	70699	OFF	ON	ON	ON	OFF	OFF
103	70668	ON	OFF	ON	ON	ON	OFF	303	70700	ON	OFF	ON	ON	OFF	OFF
104	70669	OFF	OFF	ON	ON	ON	OFF	304	70701	OFF	OFF	ON	ON	OFF	OFF
105	70670	ON	ON	ON	ON	ON	OFF	305	70702	ON	ON	ON	ON	OFF	OFF
106	70671	OFF	ON	OFF	ON	ON	OFF	306	70703	OFF	ON	OFF	ON	OFF	OFF
107	70672	ON	OFF	OFF	ON	ON	OFF	307	70704	ON	OFF	OFF	ON	OFF	OFF
108	70673	OFF	OFF	OFF	ON	ON	OFF	308	70705	OFF	OFF	OFF	ON	OFF	OFF
109	70674	ON	ON	ON	ON	ON	OFF	309	70706	ON	ON	ON	ON	OFF	OFF
110	70675	OFF	ON	ON	OFF	ON	OFF	310	70707	OFF	ON	ON	OFF	OFF	OFF
111	70676	ON	OFF	ON	OFF	ON	OFF	311	70708	ON	OFF	ON	OFF	OFF	OFF
112	70677	OFF	OFF	ON	OFF	ON	OFF	312	70709	OFF	OFF	ON	OFF	OFF	OFF
113	70678	ON	ON	ON	OFF	ON	OFF	313	70710	ON	ON	ON	ON	OFF	OFF
114	70679	OFF	ON	OFF	OFF	ON	OFF	314	70711	OFF	ON	OFF	OFF	OFF	OFF
115	70680	ON	OFF	OFF	OFF	ON	OFF	315	70712	ON	OFF	OFF	OFF	OFF	OFF
116	70681	OFF	OFF	OFF	OFF	ON	OFF								

- 열쇠 주문은 번호·개수를 신청해 주십시오.
- 번호는 희망에 맞추어 변경할 수 있습니다.
- Specify the No. and quantity when making order.
- Marking No. can be changed upon request.

특징 Feature

- 마이크로 스위치의 수에 따라 2단형 3가지에서 6단형 64가지의 회로 구성이 만들어지며, 각각 독립된 키로 조작합니다.
- 특정 오퍼레이터는 각각의 전용 열쇠를 사용하기 때문에 조작 관리가 완벽합니다.
- 콤팩트하여 공간을 차지하지 않습니다.
- 부착이 쉽습니다.
- Circuit structure of two-step four sets to six-step 64 sets can be prepared corresponding to the number of microswitches and each independent key is used.
- Operators use their own special key so the operation management is perfect.
- Compact and space-saving.
- Easy-to-install.

사항	내용
재질	본체/패널 황동봉(C3604BD) 키/황동판(C3713P)
표면 마무리	본체/크롬 도금(MBCr) 키/니켈 도금(MBNi)
열쇠가 다른 타입 수(최대)	각 열쇠 초기 번호당 1,000가지
열쇠 번호	No.0102
용도	각종 컴퓨터·경보장치·재고 관리기기
정격	AC125V·5A(저항 부하) DC30V·4A(저항 부하)
최소 적용 부하	DC5V·160mA(저항 부하)
접촉 저항	50mΩ 이하(초기치)
절연 저항	100MΩ 이상(500VDC)
내전압	(50/60Hz, 1분간) 동극 단자 AC1500V 각 단자와 비동전 금속부 사이 AC1500V
내구성	기계적 3,000만회 이상 전기적 20만회 이상
접점 소재	은 도금
사용 주위 온도	-25 ~ +85°C(동결하지 않을 것)
사용 주위 습도	85%RH 이하. 단, 5~35°C에서(결로가 없을 것)
내진동	10~55Hz 복진폭 1.5mm
내충격	50G 이상
인증 규격	U.L.(사용 SW)
비고	● 열쇠가 다른 타입도 제작합니다.

Specification	내용
Material	Main body: Free cutting brass bar (C3604BD) Key: Brass plate (C3713P)
Finish	Main body: Chrome plating (MBCr) Key: Nickel plating (MBNi)
Max. key differences	1,000 per each initial No.
Key No.:	0102
Specifications	Various computers, alarm devices and stock control equipment
Rated	AC125V·5A (resistanced load) DC30V·4A (resistanced load)
Min. applicable load	DC5V 160mA (resistanced load)
Contact resistance	50mΩ or less
Insulation resistance	100MΩ or more (500VDC)
Withstand voltage	(50/60 Hz, one minute) Between same pole terminals: AC1500V Between each terminal and non-charged metal: AC1500V
Durability	Mechanical: 30,000,000 times or more Electrical: 200,000 times or more
Contact material	Silver plating
Ambient temperature	-25°C to +85°C (non-freezing)
Operating humidity range	85%RH or less, +5°C to +35°C (non-condensing)
Vibration resistance	10 to 55Hz multiple-amplitude 1.5mm
Impact resistance	50G or more
Approved standard	U.L.

상품번호 Product No.	RoHS 10	L	제품질량(g) Mass	코드 Code
S-102-2		28	114	40396
S-102-4		34.5	119	40397
S-102-6		41	123	40398
S-102-KEY			12	표에 따름

- RoHS10 대응품
- ▲ RoHS10에 대응 가능함입니다.

오퍼레이터 키 스위치
스톱과 부착 키 스위치
마이크로 스위치

OPERATOR KEYSWITCHES