



밀폐형 접이식 평면 핸들

FOLDING FLUSH HANDLES FOR AIRTIGHTNESS

특징 Feature

- 핸들을 수납함으로써 스톱퍼가 3mm 리프트. 강력한 실드 효과를 얻을 수 있습니다.
- 접이식 평면 핸들 A-213의 키 부분을 센터로 배치한 새로운 디자인으로 패널 구멍 치수에 호환성이 있습니다.
- 도어 닫힘 상태에서 심한 진동, 충격이 가해져도 도어가 열리지 않는 안전 구조
- 좌우 겸용형
- The stopper will be lifted up 3mm when the handle is encased in the housing, providing excellent shield effects.
- New design based on Folding Flush Handle A-213 with key portion located in center and same panel drilling dimensions.
- Safety structures, so that the doors does not open further even strong vibration or impact is applied when the door is close.
- For both left-hand and right-hand use.

조임 스트록 3mm=강력 밀폐



키 No.T0230 Key

A-213N

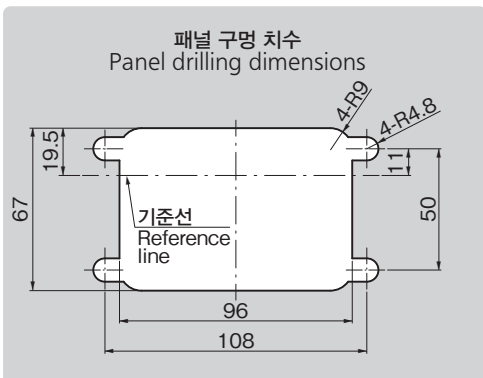
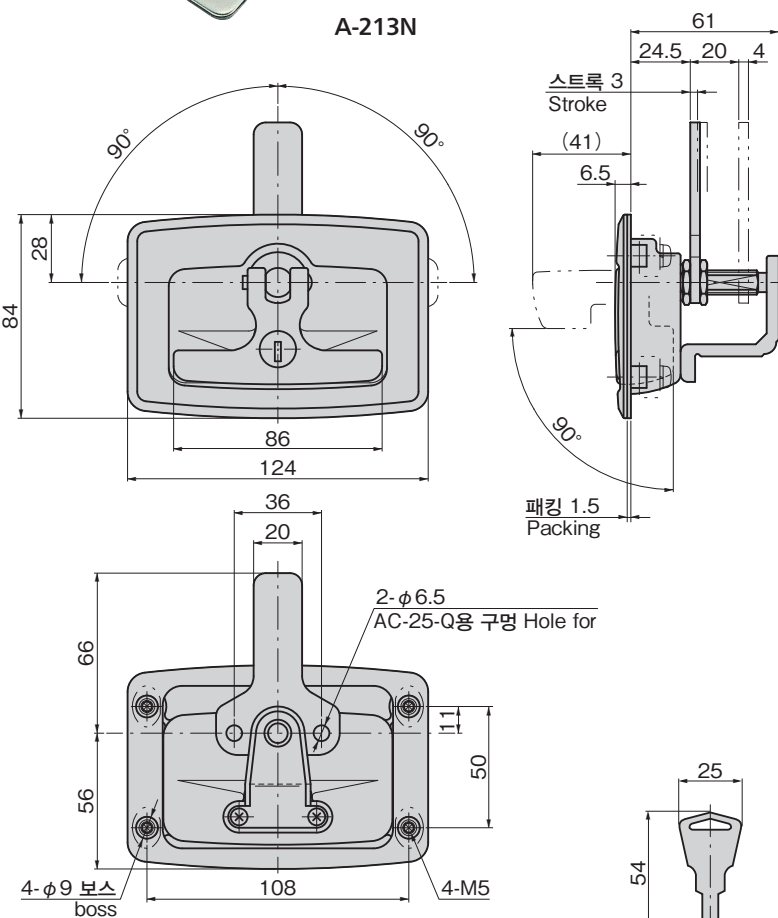

| | |
|----------------|---|
| 사양 | <ul style="list-style-type: none"> • 제품질량: 570g • 재질: 아연합금(ZDC) • 앞면 마무리: A-213N/어벤추린 크롬 도금(MZCr) • A-213N-SLV/실버 메탈릭 열처리 도장 • 열쇠 번호: T0230 • 최대 적용 판 두께: 3.5mm • 부속품: 전용 스톱퍼·나사 세트·키 2개 |
| 용도 | <ul style="list-style-type: none"> • 특장차·큐비클·진동기기 |
| 비고 | <ul style="list-style-type: none"> • 열쇠 불포함 타입도 있습니다. • 열쇠 번호 0200·R200·500 등의 키 체인지는 문의해 주십시오. • 오래 사용하기 위해 정기적으로 접동부에 고성능 윤활제를 도포하십시오. • 본 제품의 스톱퍼 부착용 너트는 풀림 방지를 위해 '풀림 방지제'를 도포할 것을 권장합니다. |
| Specifications | <ul style="list-style-type: none"> • Mass: 570g • Material: Zinc alloy (ZDC) • Finish: A-213N/Aventurine chrome plating (MZCr) • A-213N-SLV/Silver metallic baked • Key No.: T0230 • Max. applicable panel thickness: 3.5mm • Accessories: Stopper for exclusive use, a set of screws and two keys |
| Specific-use | <ul style="list-style-type: none"> • Specially equipped vehicles, cubicles and oscillation devices |
| Remarks | <ul style="list-style-type: none"> • The product without lock is also available. • To prolong the life of the product, apply a regular coating of high-performance lubricant to the sliding parts. • It is recommended that thread-locking fluid be used to prevent loosening of the mounting nut for the catch. |

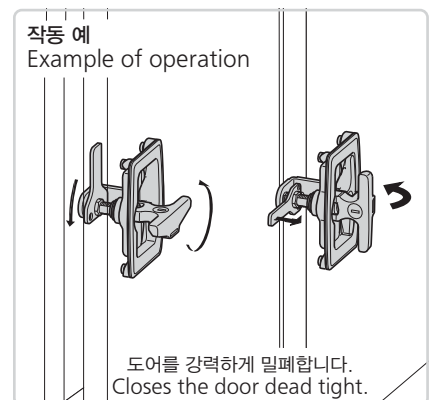

| 상품 번호 Product No. | RoHS 10 | 코드 Code |
|----------------------|------------|------------|
| A-213N | ● | 01880 |
| A-213N-SLV | ▲ | 04722 |

●: RoHS10 대응품
▲: RoHS10에 대응 가능합니다.