

레벨 어저스터

K-1276-B

스테인레스제

K-1277-B

스테인레스제



중하중 레벨링 풋 HEAVY DUTY LEVELLING FOOT

특징 Feature

- 스테인레스제로 내식성이 뛰어납니다.
- 나사부를 약 40° 꺾을 수 있어 경사진 바닥에서도 수평을 유지할 수 있습니다. (K-1277-B)
- 접지면이 크고 패드가 있어서 방진성이 뛰어납니다.
- Corrosion-resistant, stainless steel construction.
- The screw section can move through 40°, thus maintaining the horizontal even on a sloping floor. (K-1277-B)
- The wide, padded floor-contact area provides excellent vibration-proofing.



K-1276-B-30-200



K-1276-B-24-150

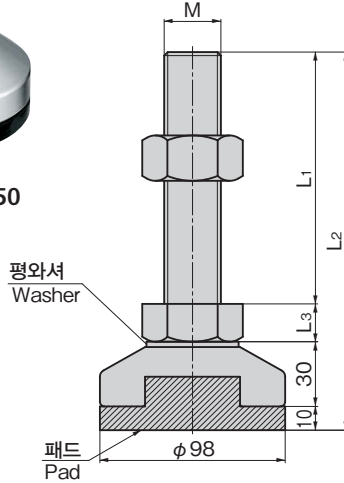

사양	<ul style="list-style-type: none"> ● 재질: 샤프트/스테인레스 강봉(SUS304) 바닥/스테인레스 강봉(SUS303) 패드/합성고무(NBR) ● 표면 마무리: 헤어 라인 마무리 ● 사용 주위 온도: -10 ~ +60°C ● 부속품: 너트
용도	● 반도체설비·의료설비·공작기계
납기	● 수입품...납기는 문의해 주십시오
Specifications	<ul style="list-style-type: none"> ● Material: Shaft: Stainless steel rod (SUS304) Foot: Stainless steel rod (SUS303) Pad: Synthetic rubber (NBR) ● Finish: Hairline buffing ● Ambient temperature: -10°C to +60°C ● Accessories: Nut
Specific-use	● Semi-conductor equipment, medical equipment, machine tools

상품명 Product No.	RoHS 10	L1	L2	L3	M	권장 하중 N/4개 Recommend load	제품질량(g) Mass	코드 Code
K-1276-B-24-150	✓	150	206	16	M24×3.0	39,200	2,135	31537
K-1276-B-24-200		200	256	16	M24×3.0	39,200	2,150	31538
K-1276-B-30-150		150	210	20	M30×3.5	49,000	2,640	31539
K-1276-B-30-200		200	260	20	M30×3.5	49,000	2,670	31540

●: RoHS10 대응품 ▲: RoHS10에 대응 가능합니다.



K-1277-B-20-100



K-1277-B-16-100

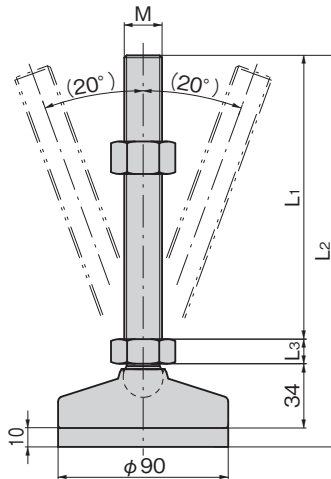

사용 예
Example of application

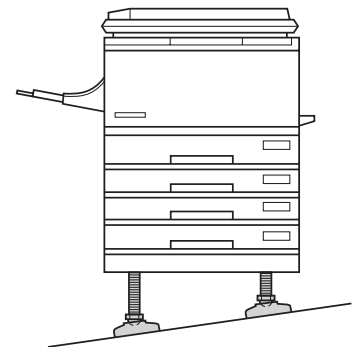

상품명 Product No.	RoHS 10	L1	L2	L3	M	권장 하중 N/4개 Recommend load	제품질량(g) Mass	코드 Code
K-1277-B-16-100	✓	100	154	10	M16×2.0	14,700	1,065	31547
K-1277-B-16-130		130	184	10	M16×2.0	14,700	1,110	31548
K-1277-B-20-100		100	157	13	M20×2.5	19,600	1,205	31549
K-1277-B-20-150		150	207	13	M20×2.5	19,600	1,330	31550

●: RoHS10 대응품 ▲: RoHS10에 대응 가능합니다.