

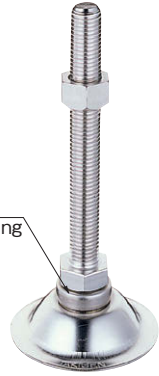

KC-1275-A-1



KC-1275-A-12

트러스트 베어링 내장
Thrust bearing built-in

어저스터 홀딩 플레이트
Adjuster braces

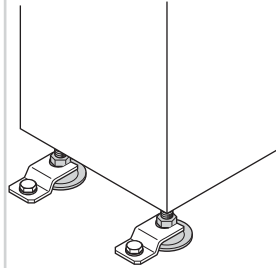

공작기계의 진동에 의한 기계의 이동을 방지합니다.
A machine tool can be fixed to prevent moves due to vibration.

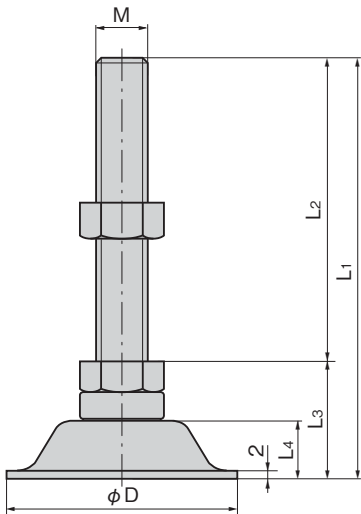

사용 예
Example of application

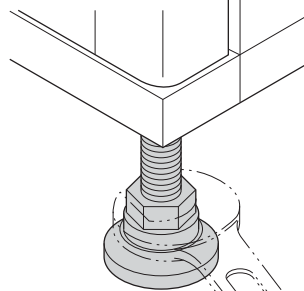

기기 설치 후의 높이 조절이 용이합니다.
It's easy to adjust level after installation.

특징 Feature

- 스텐레스제로 내식성이 뛰어납니다. (KC-1275)
- 트러스트 베어링이 들어있어서 하중이 가해진 상태에서도 높이 조절이 용이합니다. (KC-1275-A-11~14)
- 중하중용(KC-1275)
- Corrosion-resistant stainless steel is used.(KC-1275)
- Thrust bearing is built in so level can be adjusted easily even when it's loaded.(KC-1275-A-11~14)
- For heavy load use.(KC-1275)

[KC-1275-A]

- 사양
- 재질: 샤프트/스텐레스 강봉(SUS304)
바닥/냉간 압연 스텐레스 강판(SUS304)

[KC-275-A]

- 사양
- 재질: 샤프트/냉간 압조용 탄소강선(SWCH)
바닥/열간 압연 강판(SPHC)
 - 표면 마무리: 아연 도금 크로메이트 처리(MFZn-C)
- 부속품
- 육각 너트(일중)
- 용도
- 공작기계·자동판대기
- 비고
- M12는 L₂ 치수 200mm, M16은 L₂ 치수 350mm까지 제작합니다(KC-1275-A-11, 12, 13, 14은 제외).
 - 홀드 플레이트도 있습니다.
 - KC-275-A-11, 12, 13, 14는 중지품입니다.
 - KC-2275-A(티타늄제)는 중지품입니다.

[KC-1275-A]

- Specifications
- Material: Shaft: Stainless steel bar (SUS304)
Base: Cold rolled stainless steel plate (SUS304)

[KC-275-A]

- Specifications
- Material: Shaft: Carbon steel wire rods for cold heading and cold forging (SWCH)
Base: Hot rolled steel plate (SPHC)
- Accessories
- Hexagon nut (JIS type 1)
- Specific use
- Machine tools and vending machines
- Remarks
- L₂ dimension of up to 200mm for M12 and L₂ dimension of up to 350mm for M16 are available (except KC-1275-A-11, 12, 13, 14).
 - Product KC-275-A-11, 12, 13, 14 are no longer manufactured.
 - KC-2275-A (titanium) is no longer manufactured.

상품명 Product No.	RoHS 10+	L ₁	L ₂	L ₃	L ₄	φD	M	수직 사용 하중 kN Vertical load	대응 홀드 플레이트 Applicable brace	제품질량(g) Mass	코드 Code
KC-1275-A-1	●	208	180	28	18	75	M16×2.0	4.9	KC-1275-C-2	425	20981
KC-1275-A-11	●	217	180	37	18				KC-1275-C-6	443	22213
KC-1275-A-2	●	158	130	28	18				KC-1275-C-2	365	20982
KC-1275-A-12	●	167	130	37	18				KC-1275-C-6	383	22214
KC-1275-A-3	●	128	100	28	18				KC-1275-C-2	325	20983
KC-1275-A-13	●	137	100	37	18				KC-1275-C-6	343	22215
KC-1275-A-4	●	143	120	23	15	55	M12×1.75	1.96	KC-1275-C-3	185	20984
KC-1275-A-14	●	150.5	120	30.5	14				KC-1275-C-7	203	22216
KC-1275-A-5	●	67	50	17	10	37	M10×1.5 M8×1.25	1.96	KC-1275-C-4·4N	75	21733
KC-1275-A-6	●	65.5	50	15.5	10				KC-1275-C-5·5N	50	21734
KC-275-A-1	●	208	180	28	18	75	M16×2.0	4.9	KC-275-C-2	420	20634
KC-275-A-2	●	158	130	28	18				KC-275-C-2	360	20635
KC-275-A-3	●	128	100	28	18				KC-275-C-2	320	20636
KC-275-A-4	●	143	120	23	15	55	M12×1.75	1.96	KC-275-C-3	185	20637
KC-275-A-5	●	67	50	17	10				KC-275-C-4·4N	75	21714
KC-275-A-6	●	65.5	50	15.5	10	37	M10×1.5 M8×1.25	1.96	KC-275-C-4·4N	75	21714
KC-275-A-6	●	65.5	50	15.5	10				KC-275-C-5·5N	55	21715

●: RoHS10 대응품 ▲: RoHS10에 대응 가능함니다.



KC-275-RP-1



KC-275-RP-3

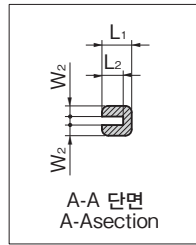
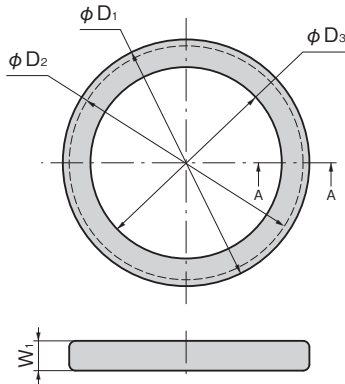

특징 Feature

- 부착 시 방진성이 우수합니다.
- 바닥면에 대한 손상을 방지합니다.
- Significantly reduces vibration.
- Prevents damage to floors.

- 시양** ● 재질: 에틸렌 프로필렌 고무(EPDM)
- 용도** ● KC-275-A, KC-1275-A 전용 고무패드입니다.

- Specifications** ● Material: Ethylene Propylene Rubber (EPDM)
- Specific use** ● Rubber pad for KC-275-A and KC-1275-A.



상품명 Product No.	RoHS 10	φD ₁	φD ₂	φD ₃	W ₁	W ₂	L ₁	L ₂	제품질량(g) Mass	코드 Code	적용 어저스터 Applicable
KC-275-RP-1	●	79	75	59	8	3	10	8	17	31503	KC-275-A-1~3 KC-1275-A-1~3
KC-275-RP-2	●	58	54	44	7	2.5	7	5	7.3	31504	KC-275-A-4 KC-1275-A-4
KC-275-RP-3	●	41	37	30	6	2	5.5	3.5	3.5	31505	KC-275-A-5~6 KC-1275-A-5~6

●: RoHS10 대응품 ▲: RoHS10에 대응 가능합니다.